

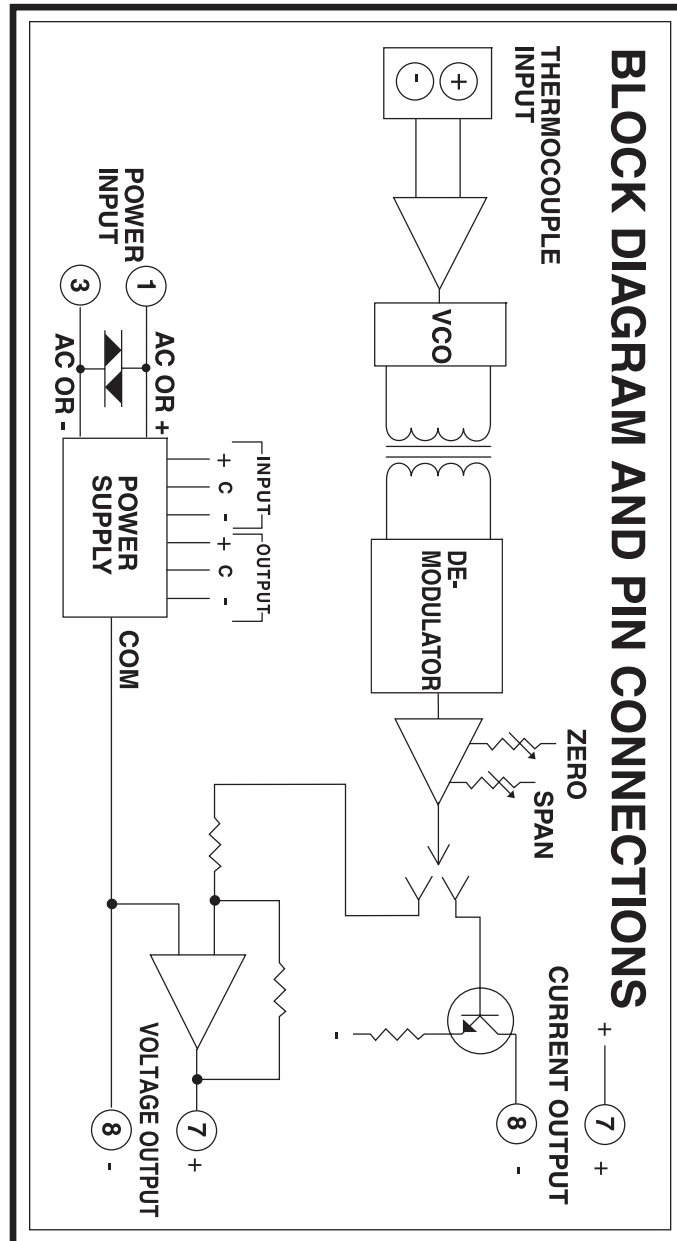

MM4130 & MM4130L ISOLATED THERMOCOUPLE INPUT TO DC TRANSMITTERS



The MM4130 is used to provide output voltages or currents proportional to a thermocouple (T/C) input signal. The basic model MM4130 provides an output proportional to the millivolt signal from the thermocouple, while linearized model MM4130L corrects the thermocouple's nonlinearity to provide an output proportional to temperature. Both models provide cold-junction compensation via a solid-state sensor embedded in the thermocouple terminal strip.

The units utilize a VCO to develop a pulse train with a duty cycle proportional to the input. This pulse train is transformer-coupled to the output stage where the duty cycle data is converted to a proportional DC output.

Upscale or downscale burnout indication is provided. Upscale is standard and is provided if burnout protection is not specified.

MODEL NUMBERS

These instructions cover the following model numbers:

MM4130: Not linearized - output proportional to input millivolts.

MM4130L: Linearized - output proportional to measured temperature.

Nonisolated thermocouple transmitters are available as models MM4100 and MM4100L, described in separate instructions.

OPTIONS

The following options are available on the MM4130 and MM4130L:

- B** Standard burnout protection is upscale. Option B provides downscale output on burnout.
- RT** Reverse-acting transmitter. The transmitter output decreases as the output increases.
- U** All circuit boards conformal coated for protection against moisture.
- DC Power** Inverter-isolated 12V or 24V power.
- LL** Superior digital output linearization (MM4130L)

CONTROLS

Two controls, ZERO and SPAN, are accessible from the top of the module. Additional controls inside the module are factory adjustments which should not be reset.



CALIBRATION

The MM4130 and MM4130L are shipped precalibrated. If there is a need to recalibrate, proceed as follows:

Refer to the instrument's label to determine your instrument's supply voltage and input and output ranges. Refer to the "Block Diagram and Pin Connections" for pin connections. Connect a precision DC voltage or current meter to the output.

Connect a calibration input to the terminal strip on the side of the module. If a thermocouple simulator is available, use it to provide the calibration input, connecting it to the transmitter with the appropriate pair of thermocouple wires. Otherwise, use copper wires to connect a precision DC millivolt source to the input.

When a millivolt source and copper wires are used it will be necessary to measure and correct for the temperature at the transmitter's input connection. Using standard tables for your thermocouple, find the millivolt level corresponding to the temperature at the input terminals. Then, at each calibration temperature, subtract this voltage from the voltage given by the thermocouple table. Remember, calibration accuracy will be no better than the accuracy of this temperature measurement.

Using standard thermocouple tables, set the input to the low end of the input range and adjust the ZERO control for the low-end output voltage or current. Increase the input to full scale and adjust the SPAN control for the full-scale output. Repeat until both readings are correct.

SPECIFICATIONS

INPUT RANGE

select **any** type thermocouple
(min span 5 mV)

OUTPUT RANGE

Voltage
select **any** range from
-10 V to +15 V,
10 mA max load (min span 0.2 V)

Current

select **any** range from
0 to 50 mA max,
24 V compliance*
(min span 1mA)
18 V compliance for ISO option if
full-scale output >20 mA

OUTPUT RIPPLE (peak-to-peak)

<0.1% of span

ACCURACY

±0.1% of span

LINEARITY

Nonlinearized, Output/Input
±0.05% of span
Linearized, Output/Temp
Linearized to match thermocouple's
millivolt-versus-temperature curve

COMMON MODE REJECTION

120 dB, DC to 60 Hz

ISOLATION

Output/Input
>500 megohms

Breakdown Voltage
>1000 VAC rms

BREAKDOWN, PWR/CIRCUITRY

>1500 VAC rms

OPERATING TEMPERATURE

14°F to 140°F/-10°C to 60°C

TEMPERATURE STABILITY

±(0.02% of span + 1.3μV)/°C max

POWER

2.5 W max
115 VAC ±10%, 50 or 60 Hz
230 VAC ±10%, 50 or 60 Hz
(DC Power Option)
12 VDC (limits 10 VDC to 15 VDC)
24VDC (limits 21 VDC to 32 DC)

Isolation, DC power supply to input
common: 10 megohms

* Compliance:

The sum of all voltage drops in the output loop cannot exceed 24 V at rated current (1200 ohms @ 20 mA).

MOUNTING

Power and output connections are made through the socket. The thermocouple input connects to the small terminal block on the side of the module (red wire to negative).

The module is designed to plug into a standard 8-pin relay socket.

Part number MP008 is a molded plastic socket suitable for mounting on a flat surface or in a 2 3/4 inch wide PVC snap track (TRK48). Socket DMP008 is a 8-pin DIN rail mounted socket.

Use CLP-1 hold-down clip if needed for vibration environment (MP008 only). A Killark HK Series explosion-proof housing with dome and 8-pin socket is available (HKB-HK2D-8).

WARRANTY

The Mighty Module Series of products carry a limited warranty of 10 + 5 years. In the event of a failure due to defective material or workmanship, during the 10 year period, the unit will be repaired or replaced at no charge. For a period of 5 years after the initial 10 year warranty, the unit will be repaired, if possible, for a cost of 10 % of the original purchase price.

Relays are not covered by the warranty.

CASE DIMENSIONS INCHES [mm]

