

Autonics PHOTOELECTRIC SENSOR BEN SERIES

MANUAL



Thank you very much for selecting Autonics products.
For your safety, please read the following before using.

Caution for your safety

- Please keep these instructions and review them before using this unit.
- Please observe the cautions that follow:
 - Warning** Serious injury may result if instructions are not followed.
 - Caution** Product may be damaged, or injury may result if instructions are not followed.
- The following is an explanation of the symbols used in the operation manual.
 - Injury or danger may occur under special conditions.

Warning

- In case of using this unit with machineries(Nuclear power control, medical equipment, vehicle, train, airplane, combustion apparatus, entertainment or safety device etc), it requires installing fail-safe device, or contact us for information on type required.**
 It may result in serious damage, fire or human injury.
- Do not disassemble and modify this unit, when it requires. If needs, please contact us.**
 It may give an electric shock and cause a fire.

Caution

- This unit shall not be used outdoors.**
 It might shorten the life cycle of the product or give an electric shock.
- Do not use this unit in place where there is flammable or explosive gas.**
 It may cause a fire or explosion.
- Please observe voltage rating.**
 It may shorten the life cycle or damage to the product.
- Do not use this unit beyond rating power and do not supply AC power(at DC power type).**
 It may result in damage to this unit.
- Please check the polarity of power and wrong wiring.**
 It may result in damage to this unit.
- Do not use this unit in place where there is vibration or impact.**
 It may result in damage to this unit.
- In cleaning the unit, do not use water or an oil-based detergent.**
 It might cause an electric shock or fire that will result in damage to the product.

Ordering information

BEN 10M - T D T

Output	R	Contact output(Relay)
	T	Solid-state output(TR)
Power supply	D	DC power
	F	Free power
Detecting type	T	Through-beam
	M	Retroreflective
	P	Retroreflective with polarizing filter
	D	Diffuse reflective
Detecting distance	M	Unit : m
		Unit : mm
Photoelectric sensor	BEN	Series name

Control output circuit diagram

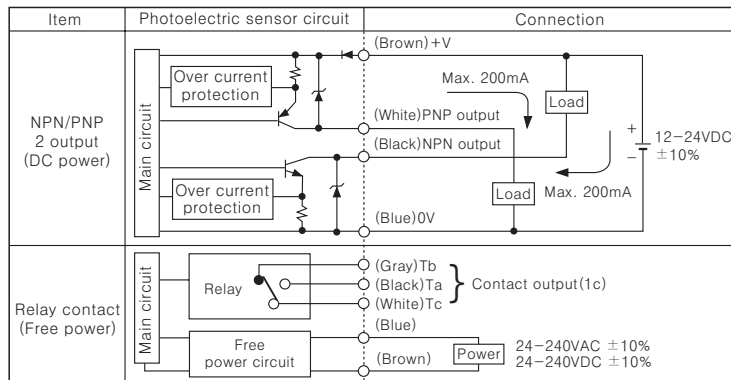

*The above specifications are changeable at anytime without notice.

Dimension

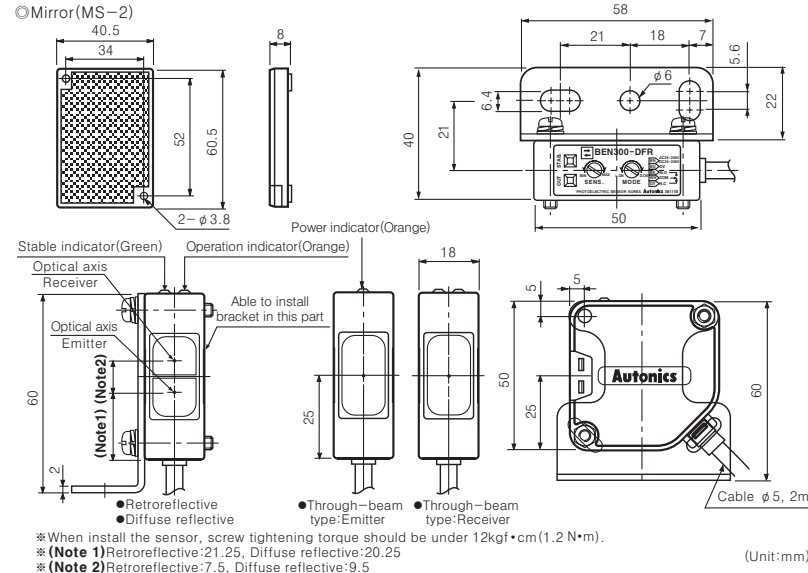

Specification

Type	Free power, Relay contact output				DC power, Solid state output			
	Through-beam	Retroreflective(•1)	Retroreflective(•1) (with polarizing filter)	Diffuse reflective	Through-beam	Retroreflective(•1)	Retroreflective(•1) (with polarizing filter)	Diffuse reflective
Model	BEN10M-TFR	BEN5M-MFR	BEN3M-PFR	BEN300-DFR	BEN10M-TDT	BEN5M-MDT	BEN3M-PDT	BEN300-DDT
Detecting distance	10m	0.1 to 5m	0.1 to 3m	300mm(100×100mm non-glossy white paper)	10m	0.1 to 5m	0.1 to 3m	300mm(100×100mm non-glossy white paper)
Detecting target	Opaque materials of Min. φ16mm	Opaque materials of Min. φ60mm	Transparent, Translucent, Opaque materials	Transparent, Translucent, Opaque materials	Opaque materials of Min. φ16mm	Opaque materials of Min. φ60mm	Transparent, Translucent, Opaque materials	Transparent, Translucent, Opaque materials
Hysteresis			Max. 15% at detecting distance				Max. 15% at detecting distance	
Response time	Max. 20ms				Max. 1ms			
Power supply	24-240VAC ±10% 50/60Hz, 24-240VDC ±10%(Ripple P-P:Max. 10%)				12-24VDC ±10%(Ripple P-P:Max. 10%)			
Power consumption	Max. 4VA				Max. 50mA			
Current consumption								
Light source	Infrared LED(modulated)	Red LED (modulated:660nm)	Infrared LED (modulated)		Infrared LED(modulated)	Red LED (modulated:660nm)	Infrared LED (modulated)	
Sensitivity adjustment	Adjustable VR				Adjustable VR			
Operation mode	Selectable Light ON or Dark ON by switch							
Control output	•Relay contact output [Relay contact capacity:30VDC 3A of resistive load, 250VAC 3A of resistive load Relay contact composition:1c				•NPN/PNP 2 output •NPN open collector output t ₊ Load voltage:Max. 30VDC, Load current:Max. 200mA, Residual voltage:Max. 1V •PNP open collector output t ₋ Output voltage Min. (Power supply-2.5)V, Load current:Max. 200mA			
Service life(Relay output)	Mechanically:Min. 50,000,000 operation, Electrically:Min. 100,000 operation							
Protection circuit	Reverse polarity protection, Short-circuit protection							
Light receiving element	Built-in IC type photo diode							
Indication	Operation indicator:Orange, Stable indicator:Green(The orange lamp on Emitter of through-beam type is for power indication)							
Connection	Outgoing cable							
Insulation resistance	Min. 20MΩ (500VDC)							
Insulation type	(•2)							
Noise strength	±1000V the square wave noise(pulse width:1μs) by the noise simulator				±240V the square wave noise(pulse width:1μs) by the noise simulator			
Dielectric strength	1500VAC 50/60Hz for 1minute							
Vibration	Mechanical 1.5mm amplitude at frequency of 10 to 55Hz in each of X, Y, Z directions for 2 hours							
Shock	Mechanical 500m/s ² (50G) in X, Y, Z directions for 3 times							
Ambient illumination	Sunlight : Max. 11,000lx, Incandescent lamp : Max. 3,000lx							
Ambient temperature	-20 to +65°C(non-freezing condition), Storage : -25 to +70°C							
Ambient humidity	35 to 85%RH, Storage : 35 to 85%RH							
Protection	IP50(IEC specification)							
Material	Case, Case cover:Heat resistant ABS, Lens:PC(with polarizing filter:PMMA)							
Cable	φ5.0mm, 5P, Length:2m(Emitter of through-beam type:φ5.0mm, 2P, Length:2m)				φ5.0mm, 4P, Length:2m(Emitter of through-beam type:φ5.0mm, 2P, Length:2m)			
Accessory	Individual Mirror(MS-2)				Common Mirror(MS-2)			
Net weight	Approx. 354g	Approx. 208g	Approx. 195g	Approx. 342g	Approx. 200g	Approx. 187g	Approx. 187g	Approx. 187g
Approval	CE							

*(•1)The sensing range and the sensing object of the retroreflective sensor are specified with using the MS-2 reflector. The sensing ranges of the retroreflective sensor in the above table are identified as the possible setting ranges of the MS-2 reflector. The sensor can detect on object under 0.1m apart.
 *(•2) □ Mark indicated that equipment protected throughout by double insulation or reinforced insulation.

Connection

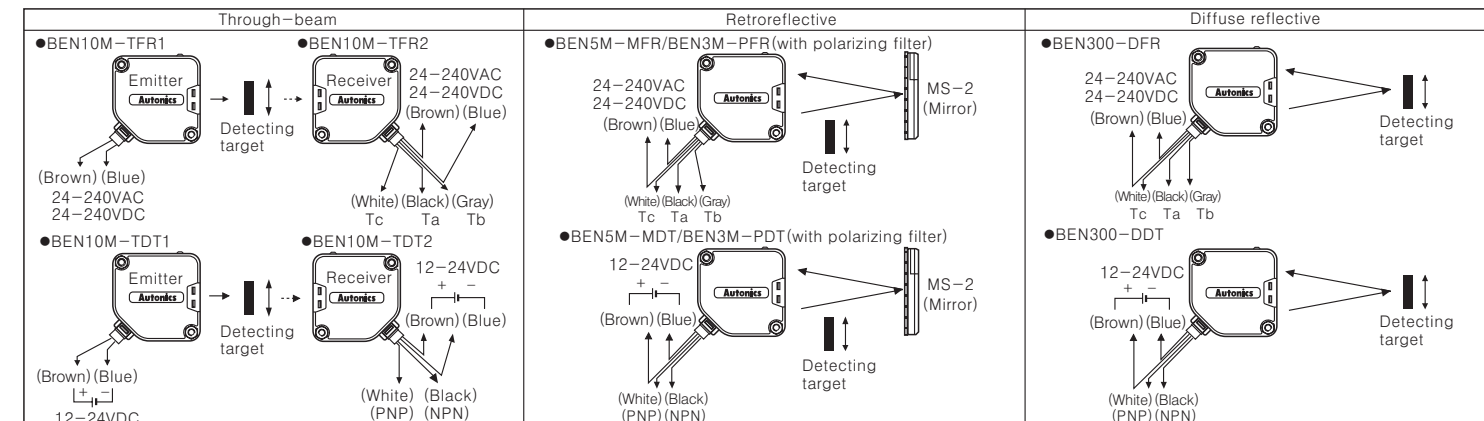

Operation mode

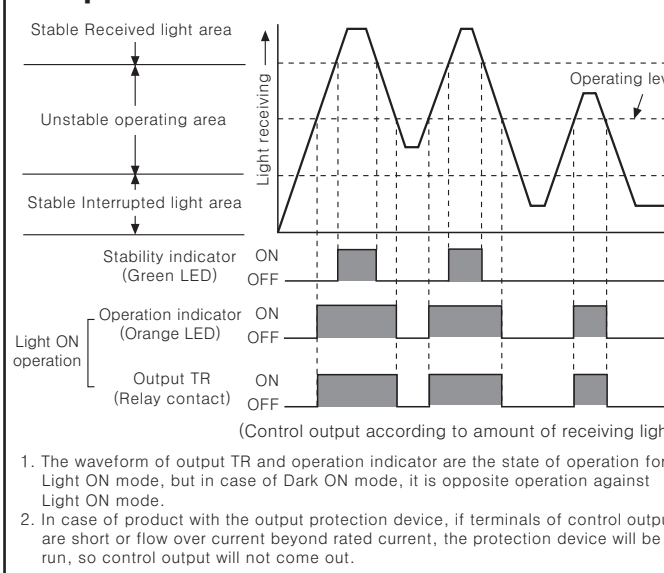

- The waveform of output TR and operation indicator are the state of operation for Light ON mode, but in case of Dark ON mode, it is opposite operation against Light ON mode.
- In case of product with the output protection device, if terminals of control output are short or flow over current beyond rated current, the protection device will be run, so control output will not come out.

Mounting & Adjustment

- Through-beam type**
 - Supply the power to the photoelectric sensor, after setting the emitter and the receiver in face to face.
 - Set the receiver in center of position where indicator turns on, as adjusting the receiver and the emitter right and left, up and down.
 - Fix both units tightly after checking that the unit detects the target.

*If the detecting target is translucent body or smaller than φ16mm, it might not detect the target cause light passed.
- Retroreflective type**
 - Supply the power to the photoelectric sensor, after setting the photoelectric sensor and the mirror(MS-2) in face to face.
 - Set the photoelectric sensor in the position which indicator turns on, as adjusting the mirror or the sensor right and left, up and down.
 - Fix both units tightly after checking that the unit detects the target.

*If use more than 2 photoelectric sensors in parallel, the space between them should be more than 30cm.
 *If reflectance of target is higher than non-glossy white paper, it might cause malfunction by reflection from the target when the target is near to photoelectric sensor. Therefore put enough space between the target and photoelectric sensor or the surface of target should be installed at an angle of 30~45° against optical axis. (When detect target with high reflectance near by, photoelectric sensor with the polarizing filter should be used.)
- Diffuse reflective type**
 - Even though the diffuse reflective type is set at max. sensitive position, sensitivity of the sensor must be adjusted the according to the existence of the reflective material in background.
 - Set the target at a position to be detected by the beam, then turn the adjuster until point (a) where the indicator turn on from min. position of the adjuster.
 - Take the target out of the photoelectric sensor, then turn the adjuster until point (b) which the indicator turns on, if the indicator does not turn on, max. sensitive position will be point (b).
 - Set the adjuster at the middle of two switching point (a), (b).

*The detecting distance indicated on specification chart is against 100×100mm of non-glossy white paper. Be sure that it can be different by size, surface and gloss of target.

Caution for using

- Intercept a strong source of light as like sunlight, spotlight within inclination angle range of photoelectric sensor.
- The photoelectric sensor may cause malfunction under the fluorescent lamp light, so be sure to use cut-off light with panel.
- When more than 2 sets of Through-beam types sensors are used closely, it might cause interference each other. Be sure to put enough space between them in order to avoid malfunction.
- When more than 2 sets of diffuse reflection types are installed adjacently, it can be occurred malfunction by light beam from the other target. So it must be installed at an enough interval.
- If photoelectric sensor is installed at flat part, it might cause malfunction by reflection light from flat part. Be sure to put space between photoelectric sensor and ground.
- When wire the photoelectric sensor with high voltage line, power line in the same conduit, it may cause malfunction or mechanical trouble. Therefore please wire separately or use different conduit.
- Avoid installing the unit as following place.
 Corrosive gas, oil or dust, strong flux, noise, sunlight, strong alkali, acid.
- In case of connect DC relay as inductive load to output, please remove surges by using diode or varistor.
- The photoelectric sensor cable shall be used as short as possible, because it may cause malfunction by noise through the cable.
- When it is stained by dirt at lens, please clean the lens with dry cloth, but don't use an organic materials such as alkali, acid, chromic acid.
- When use switching power supply as the source of supplying power, F.G terminal shall be good earth ground and condenser for removing noise shall be installed between OV and F.G terminal.

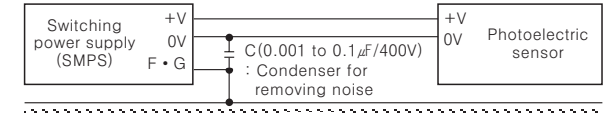

*It may cause malfunction if above instructions are not followed.

Major products

- PROXIMITY SENSOR
- PHOTOELECTRIC SENSOR
- AREA SENSOR
- FIBER OPTIC SENSOR
- DOOR/DOOR SIDE SENSOR
- PRESSURE SENSOR
- ROTARY ENCODER
- COUNTER
- TIMER
- TEMPERATURE CONTROLLER
- TEMPERATURE/HUMIDITY TRANSDUCER
- POWER CONTROLLER
- PANEL METER
- TACHO/LINE SPEED/PULSE METER
- DISPLAY UNIT
- SENSOR CONTROLLER
- SWITCHING POWER SUPPLY
- GRAPHIC PANEL
- STEPPING MOTOR & DRIVER
- LASER MARKING SYSTEM(CO₂, Nd:YAG)

Autonics Corporation
<http://www.autonics.com>

Satisfiable Partner For Factory Automation

HEAD QUARTERS :
 41-5, Yongdang-dong, Yangsan-si, Gyeongsang, 626-847, Korea

OVERSEAS SALES :
 Bldg. 402 3rd Fl., Bucheon Techno Park, 193, Yakdae-dong, Wornmi-gu, Bucheon-si, Gyeonggi-do, 420-734, Korea
 TEL: 82-32-610-2730 / FAX: 82-32-329-0728
 E-mail : sales@autonics.com