

TIMER LE3S SERIES

MANUAL



Thank you very much for selecting Autonics products.
For your safety, please read the following before using.

Caution for your safety

- Please keep these instructions and review them before using this unit.
- Please observe the cautions that follow:
 - Warning** Serious injury may result if instructions are not followed.
 - Caution** Product may be damaged, or injury may result if instructions are not followed.
- The following is an explanation of the symbols used in the operation manual.
 - caution: Injury or danger may occur under special conditions.

Warning

- In case of using this unit with machineries (Nuclear power control, medical equipment, vehicle, train, airplane, combustion apparatus, entertainment or safety device etc), it requires installing fail-safe device, or contact us for information required.**
It may result in serious damage, fire or human injury.
- This must be mounted on panel.**
It may give an electric shock.
- Do not repair or checkup when power on.**
It may give an electric shock.
- Do not disassemble and modify this unit, when it requires. If needs, please contact us.**
It may give an electric shock and cause a fire.

Caution

- This unit shall not be used outdoors.**
It might shorten the life cycle of the product or give an electric shock.
- Please observe specification rating.**
It might shorten the life cycle of the product and cause a fire.
- Do not use the load beyond rated switching capacity of Relay contact.**
It may cause insulation failure, contact melt, contact failure, relay broken, fire etc.
- In cleaning the unit, do not use water or an organic solvents.**
It might cause an electric shock or fire that will result in damage to the product.
- Do not use this unit at place where there are flammable or explosive gas, humidity, direct ray of the sun, radiant heat, vibration, impact etc.**
It may cause explosion.
- Do not inflow dust or wire dregs into inside of this unit.**
It may cause a fire or mechanical trouble.

Ordering information

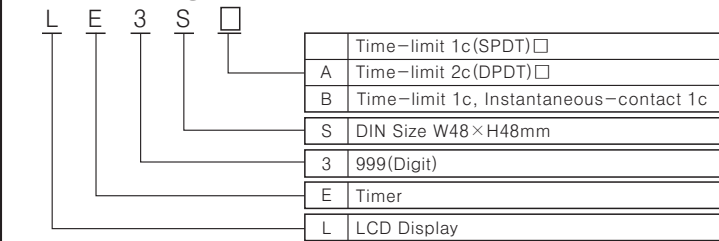

Front panel identification

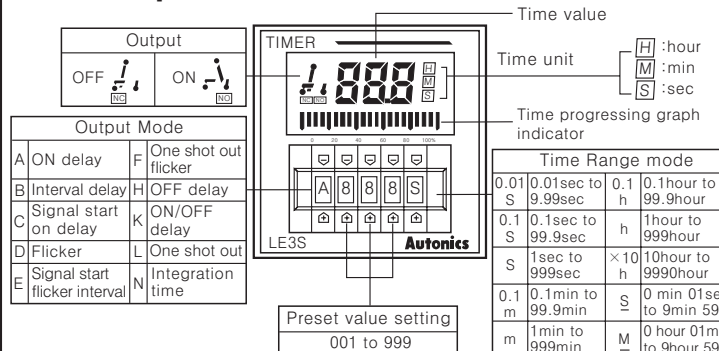

*The above specification are changeable without notice anytime.

Dimensions

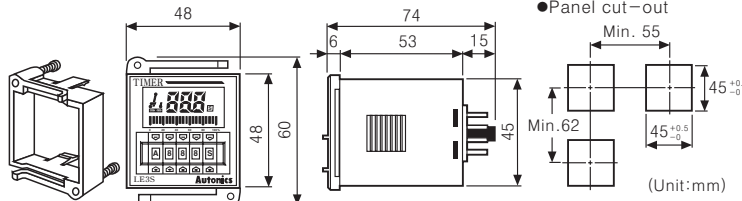

Specifications

Model	LE3S	LE3SA	LE3SB
Function	Multi operating, Multi time	MULTI time, Power ON Delay	
Power supply	24-240VAC 50/60Hz, 24-240VDC		
Display method	LCD Display		
Allowable voltage range	90 to 110% of rated voltage		
Power consumption	Max. 2.5VA (240VAC 50/60Hz) Max. 1W(240VDC)	Max. 3.3VA(240VAC 50/60Hz) Max. 1.5W(240VAC)	
Return time	Max. 0.2sec	Max. 0.1sec	
Min. input signal	START input INHIBIT input RESET input	Min. 20ms	
Input	START input INHIBIT input RESET input	• No-voltage input Shot-circuit : Impedance(Max. 1kΩ), Residual voltage : Max. 0.5VDC Open-circuit : Impedance(Min. 100kΩ)	
Control output	Type	Time-limit : SPDT(1c)	Time-limit : DPDT(2c)
Capacity	250VAC 5A resistive load	250VAC 3A resistive load	
Output mode	A, B, C, D, E, F, H, K, L, N		
Ambient temperature	-10 to 55°C (at non-freezing status)		
Storage temperature	-25 to 65°C (at non-freezing status)		
Ambient humidity	35 to 85%RH		
Deviation	Power Start: Setting error Max. ±0.01% ±0.05sec	Max. ±0.01% ±0.05sec	
Voltage error	Signal Start: Max. ±0.005% ±0.03sec		
Temperature error			
Insulation resistance	Min. 100MΩ (at 500VDC)		
Dielectric strength	2000VAC 50/60Hz for 1 minute		
Noise strength	±2kV the square wave noise (pulse width:1μs) by the noise simulator		
Vibration	Mechanical Malfunction	0.75mm amplitude at frequency of 10 to 55Hz in each of X, Y, Z directions for 1hour 0.5mm amplitude at frequency of 10 to 55Hz in each of X, Y, Z directions for 10 minutes	
Shock	Mechanical Malfunction	300m/s ² (Approx. 30G) in X, Y, Z directions for 3 times 100m/s ² (Approx. 10G) in X, Y, Z directions for 3 times	
Relay life cycle	Electrical	Min. 100,000 times (250VAC 5A resistive load)	Min. 10,000,000 times (250VAC 3A resistive load)
Weight	Approx. 100g		Approx. 105g

Connections

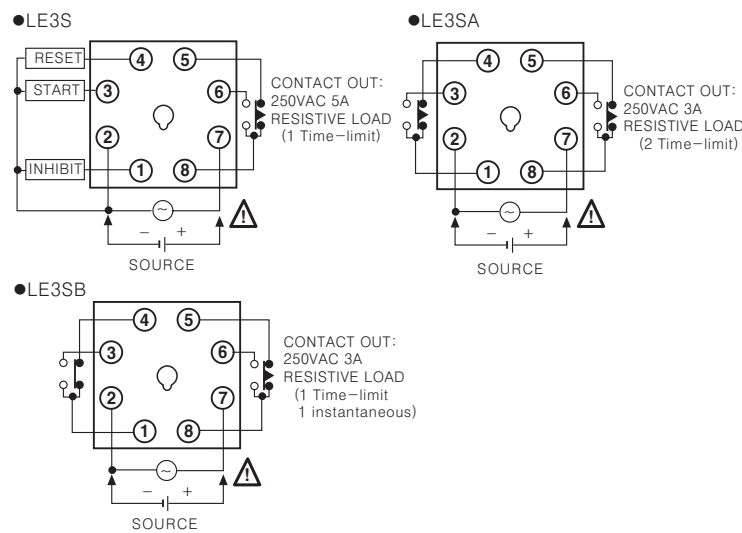

Up/Down mode

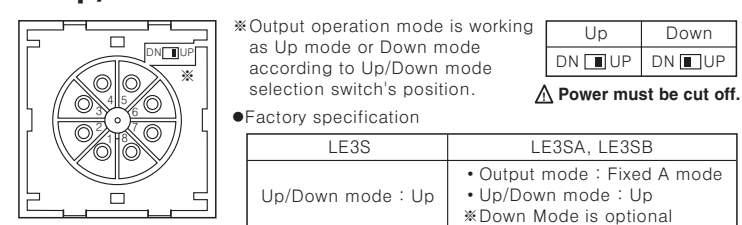

Output operation mode

LE3S

This product has 10 output mode from A to N by digital switch in front.
T=Preset value, T>Ta, T=T1+T2+T3, T>Ta+Tb

Mode

Time chart

A

ON Delay

Interval Delay

B

Interval Delay

C

ON Delay

D

Flicker

E

Flicker

F

One Shot Out Flicker

H

OFF Delay

1. Time progress when START signal is applied.
2. The output will be ON when the preset value is equal to the display value.
3. When the setting value is equal to the display value, if START signal is OFF, the output turns off, the display value is returned to initial state.
4. When the RESET signal is applied, the display value is returned to the initial state.
*When the setting value is bigger than the display value, if START signal turns off, the display value is returned to initial state.

1. Time proceeds when START signal is ON.
2. The output & display value is held when the setting value is equal to the display value.
3. When the RESET signal is applied, the display value is returned to the initial state.
*Even though setting signal is applied continuously, the signal after the second is not detected.

1. Time progress repeatedly when the START signal is ON.
2. The output also operates from NC to NO, and from NO to NC repeatedly.
3. If the START signal is OFF, it is returned to initial state.

1. Time progress repeatedly when the START signal is ON.
2. The output also operates from NC to NO, and from NO to NC repeatedly.
3. If the RESET signal is ON, it is returned to initial state.
*No need to apply start signal continuously.

1. Time progress from initial value to the setting value repeatedly and the output operates as one-shot (0.3sec), when the START signal is ON.
2. If the RESET signal turns on, it is returned to initial state.
*No need to apply the START signal continuously.

1. The START signal & the output is ON at the same time, the output will be reset and the display value is held after the setting time.
2. If the RESET signal is ON, the display value is returned to initial state.
*If the START signal is applied continuously, the output will be ON but time is not progressing.

K

ON/OFF Delay

L

Interval Delay

N

Integration Time

1. The START signal & the output is ON at the same time, the output will be reset when setting value is equal to display value. The START signal is OFF & the output is ON at same time, the output is ON when setting value is equal to display value.
2. If the START signal is applied continuously, the output turns on but time is returned to the initial state.
3. If the reset signal turns on, the display value is returned to initial state.

1. When the START signal is applied, the output turns on and the time is progressing at the same time.
2. When the time reach at the setting value the output will be reset, and the display value is held.
3. If the RESET signal is applied, the display value is returned to initial state.

1. When the start signal is applied, the time proceeds.
2. When the output signal does not come out, if turn the start signal off, then time will be held.
3. If the reset signal is applied, the display value is returned to initial state.

*Initial state : The output is OFF, the display value is "0". (At Up mode)
*When use D, E, F output mode: If set the fine short, it may not work due to response time of relay contact. Please set the min. setting time over 100ms.

LE3SA, LE3SB

LE3SA

Power 2-7
Time-limit contact NC 8-5
Time-limit contact NO 1-3

LE3SB

Power 2-7
Time-limit contact NC 8-5
Instantaneous contact NO 8-6
Instantaneous contact NC 1-4
Instantaneous contact NO 1-3

* t : Setting time, Rt : Resetting (Min. 100ms)

Caution for using

- AC Power: It is able to connect power to the terminals (2 to 7) without distinguish the polarity.
- DC Power: Be sure the polarity of (+), (-).
- When apply the power voltage, please apply rating power at the moment by switch, relay etc. in order to reduce the time error.
- Please use the transformer which has been insulated between primary and secondary and not grounded in secondary.
- Do not control the plural number of Timer with one transistor for input at the same time.

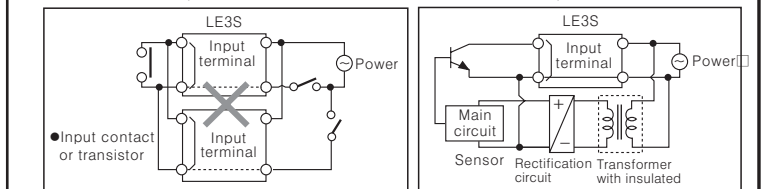

- When set the time setting as 000, control output will not come out.
- Do not connect input signal to terminal 2, it may cause inner circuit broken.
- Do not change the time unit, time setting value, output operation mode (LE3S) while it is running. Therefore continue to set after cutting off power.
- Do not use this unit at below places.
 - It shall be used indoor
 - Altitude Max. 2000m
 - Pollution Degree 2
 - Installation Category II.

*It may cause malfunction if above instructions are not followed.

Main products

- COUNTER
- TIMER
- TEMPERATURE CONTROLLER
- PANEL METER
- TACHO/LINE SPEED/PULSE METER
- DISPLAY UNIT
- PROXIMITY SENSOR
- PHOTOELECTRIC SENSOR
- FIBER OPTIC SENSOR
- PRESSURE SENSOR
- ROTARY ENCODER
- SENSOR CONTROLLER
- POWER CONTROLLER
- STEPPING MOTOR & DRIVER & CONTROLLER
- LASER MARKING SYSTEM (CO₂, Nd:YAG)

Autonics Corporation
http://www.autonics.com

Satisfiable Partner For Factory Automation

HEADQUARTERS : 41-5, Yongdang-ri, Ulsang-eup, Yangsan-si, Gyeongsang, 626-847, Korea

INTERNATIONAL SALES : Bldg. 402 3rd Fl., Bucheon Techno Park, 193, Yakdae-dong, Wonmi-gu, Bucheon-si, Gyeonggi-do, 420-734, Korea
TEL: 82-32-610-2730 / FAX: 82-32-329-0728
E-mail : sales@autonics.net

EP-KE-02-013H