



# 4009

8 dBi GAIN

915MHz BAND 3 ELEMENT HEAVY DUTY YAGI

## FEATURES

- Rugged and Weatherproof
- Lightweight Aluminum
- SS Mounting Hardware Included
- Wind Survival to 125 MPH

## DESCRIPTION

Yagi antennas achieve more gain than vertical antennas by concentrating radiation in a single direction. Their reduced gain from the back end helps keep other signals from interfering with normal operation. The front to back ratio is an important characteristic of a yagi antenna.

A yagi antenna can be operated with the elements mounted vertically or horizontally, but the most common use

for industrial wireless is vertical. The transmitting and receiving antenna must both have the same element polarization for satisfactory operation. A large loss in signal is experienced when the elements are crossed polarized.

When a vertical omnidirectional antenna is used on the control end of a polling system, a yagi can be used on each slave unit for maximum gain

and reduction in interference due to the front to back ratio gain reduction.

These heavy duty yagi antennas are constructed of 1" aluminum U channel with 3/8" solid elements. All exposed areas are coated with UV polyester. The balun assembly is filled and sealed with elastomeric thermoplastic.

The connector is a Type N Female on a 12" teflon pigtail cable.

## SPECIFICATIONS

### ELECTRICAL

#### GAIN

8dBi  
Front to Back Ratio  
15dB

#### FREQUENCY

900-930MHz

#### IMPEDANCE

50 ohms

#### VSWR

<2:1

#### VERT BEAM WIDTH

70°

#### HORIZ BEAM WIDTH

90°

#### POWER RATING

300 watts

#### CONNECTOR

Type N Female on 12" Teflon  
Pigtail

### MECHANICAL

#### MATERIAL

1" aluminum U channel boom  
3/8" solid elements

#### FINISH

UV inhibited polyester coat

#### LENGTH

18"

#### WEIGHT

<4 lbs.

#### MOUNT

Stainless Hardware for  
2 3/8" mast

#### FLAT PLATE AREA

.147 ft<sup>2</sup>

#### WIND RATING

125 MPH

#### WIND LOAD

8.8 lbs.

### HORIZONTAL PATTERN

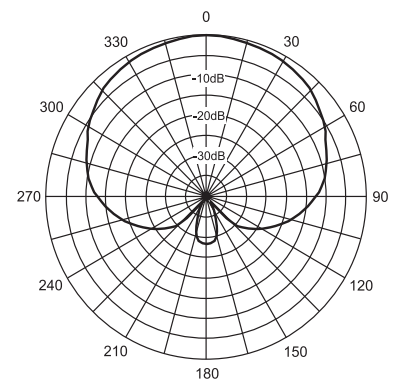

### VERTICAL PATTERN

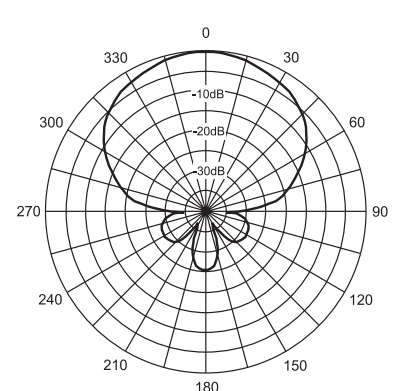

## ORDERING INFORMATION

4009 8dBi Gain, 3 Element, Heavy Duty Yagi Antenna QTY \_\_\_\_\_

## ACCESSORIES

4026	Bulkhead Connector Type N Female to Type N Female	QTY _____
4011	Bulkhead Surge Protector Type N Male to Type N Female	QTY _____
4035	Bulkhead Surge Protector Type N Female to Type N Female	QTY _____
4073	Two Antenna Coupler, Transmit and Receive, 2-Port 900 MHz	QTY _____
4051	Receive Only, 2 to 4 Antenna Coupler 4-Port 900 MHz	QTY _____
4062	50 Ohm Termination, For Unused Ports On P/N 4051,4061	QTY _____

For more accessories, see the **ACCESSORIES** section of this catalog (Page 51).

## CABLES

RP = Reverse Polarity

CPT2	2 Ft WBC195 Cable w/ RP-SMA Male & Type N Male Connector	QTY _____
CPT6	6 Ft WBC195 Cable w/ RP-SMA Male & Type N Male Connector	QTY _____
CPT10	10 Ft WBC195 Cable w/ RP-SMA Male & Type N Male Connector	QTY _____
CPT-X	Custom length WBC195 Cable w/ RP-SMA Male & Type N Male Connector Specify length from 12 inches to 120 Inches                      Length _____ Inches	QTY _____
C195NM-NM-2	2 Ft WBC195 Cable w/ Type N Male & Type N Male Connector	QTY _____
C400NM-NF-10	10 Ft WBC400 Cable w/ Type N Male & Type N Female Connector	QTY _____
C400NM-NF-20	20 Ft WBC400 Cable w/ Type N Male & Type N Female Connector	QTY _____
C400NM-NF-30	30 Ft WBC400 Cable w/ Type N Male & Type N Female Connector	QTY _____
C400NM-NF-40	40 Ft WBC400 Cable w/ Type N Male & Type N Female Connector	QTY _____
C400NM-NF-50	50 Ft WBC400 Cable w/ Type N Male & Type N Female Connector	QTY _____
C400NM-NF-75	75 Ft WBC400 Cable w/ Type N Male & Type N Female Connector	QTY _____
C400NM-NF-100	100 Ft WBC400 Cable w/ Type N Male & Type N Female Connector	QTY _____
C400NM-NM-10	10 Ft WBC400 Cable w/ Type N Male & Type N Male Connector	QTY _____
C400NM-NM-20	20 Ft WBC400 Cable w/ Type N Male & Type N Male Connector	QTY _____
C400NM-NM-30	30 Ft WBC400 Cable w/ Type N Male & Type N Male Connector	QTY _____
C400NM-NM-40	40 Ft WBC400 Cable w/ Type N Male & Type N Male Connector	QTY _____
C400NM-NM-50	50 Ft WBC400 Cable w/ Type N Male & Type N Male Connector	QTY _____
C400NM-NM-75	75 Ft WBC400 Cable w/ Type N Male & Type N Male Connector	QTY _____
C400NM-NM-100	100 Ft WBC400 Cable w/ Type N Male & Type N Male Connector	QTY _____

For more cables, see the **ACCESSORIES** section of this catalog (Page 52).