

# DR9011 / DR9021 WIRELESS DATA ACQUISITION SYSTEM

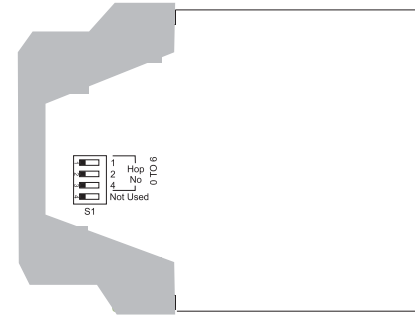

DR9011 Switches

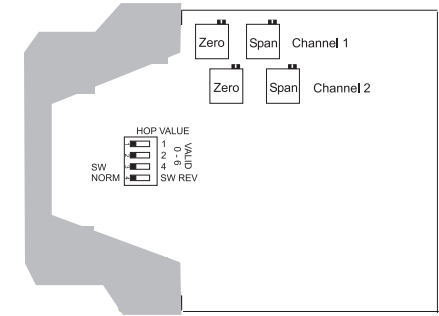

DR9021 Switches and Potentiometers

Figure 1

A wireless system is very simple to setup and operate. To ensure optimal performance, please read and carefully follow the instructions in this manual.

## SYSTEM CONTENTS

Your system includes this manual, a DR9011 Wireless Transmitter and at least one DR9021 Wireless Receiver.

The only prepared cable required is the coaxial cable that connects to the wireless product and the antenna. All other connections are field wiring from the plug-in terminal blocks to the user's input and output devices.

Antennas will be required for each product.

## DESCRIPTION

The Wireless Point-to-Point System requires only one DR9011 Transmitter and at least one DR9021 Receiver. The system supports an unlimited number of receivers.

The DR9011 is an RF transmitter that will accept both analog and digital inputs in the form of contacts, open collector NPN transistors, or N channel MOSFET transistors.

A 12 bit A/D converter is used to digitize the analog data. Analog data and switch status is then transmitted to the companion DR9021 Receivers.

The DR9021 RF Receiver receives RF signals from the DR9011 Transmitter and reconstructs the analog signals and switch status. The analog signals are reconstructed as 4/20mA outputs.

When the transmitter has a dual channel input, the DR9021 Receiver has a 4/20mA output for each channel. If the transmitter has a single channel analog input, the DR9021 provides two 4/20mA outputs proportional to the single input.

In the Signal Strength Mode of operation, analog channel 2 provides a 4/20mA output proportional to the received RF signal level.

This output is valuable for insuring adequate signal level and to help in the pointing of directional antennas. See HOP SEQUENCE SETTING for details.

Switch(digital) outputs are provided as isolated open collector NPN transistors.

A DIP Switch on the DR9021 PC board allows selection of Normal Acting or Reverse Acting (failsafe) digital outputs. (See Figure 1)

The system can be ordered as a 900MHz, 923MHz, or 2.4GHz system. All three systems take advantage of the unlicensed ISM frequency bands. The radios use frequency hopping, spread spectrum technology to eliminate interference and to allow multiple transmitters to operate in the same locale without interference. Each of the three frequency bands has 7 different user selectable frequency hopping sequences to allow up to 21 transmitters to work in the same locale. The transmitter module hops through 25 channels with any 1 of 7 hop sequences per frequency band. A DIP Switch on the PC board is used to set the hopping sequence.

Both the DR9011 and DR9021 have 2 point isolation between input, output and power source, additionally, the DR9011 dual channel DC input has individual isolation for each input channel.

The isolation makes the product useful for measuring input signals with high common mode voltages and for breaking ground connections to eliminate ground loops.

Pluggable screw terminal blocks allow easy wiring and removal of products.

All of the DR Series of products provide transient protection to help eliminate damage from lightning and from other transients created on the power and signal leads.

## HOP SEQUENCE SETTING

To operate as a system both the DR9011 and the DR9021 must have the same Hop Sequence setting. To set the Hop Sequence:

1. Remove the power and all connections from the unit.
2. Squeeze the two tabs that hold the case front section to the rear section and pull the case apart. The circuit board is attached to the front section and will slide out of the case.
3. Locate the 4 position DIP switch just inside of the front panel ( See Figure 1). The switches work in binary.

Switch 1 = Binary 1 (HOP 1)  
Switch 2 = Binary 2 (HOP 2)  
Switch 3 = Binary 4 (HOP 4)  
Switch 4 = Normal / Reverse Acting (DR9021 Only)

To set the Hop Sequence desired, close the switches as follows:

HOP SEQUENCE	CLOSE SWITCHES
0	All Switches Open
1	1
2	2
3	2, 1
4	3
5	3, 1
6	3, 2

Units are normally shipped from the factory with the HOP sequence set to "0".

## SIGNAL STRENGTH MODE

The DR9021 can provide a 4/20mA output on analog channel 2 which is proportional to the received signal strength from the remote transmitter. The signal strength may be monitored continuously but with the loss of channel 2 analog for data acquisition, or it may be used as necessary and then disabled so channel 2 output is data from the remote transmitter.

The Hop sequence should be set before using the Signal Strength capability. With the power On or Off, put the DIP switch setting for a value of 7 (SW 1, 2, and 3 ON). This places analog channel 2 in the Signal Strength Mode.

When use of the signal level is complete, place the DIP switch back in the Hop Sequence value (power On or Off) so the Hop sequence will not change if power goes through an Off/On event.

The 4th position of the DIP switch has no effect on the signal strength output. Analog channel 1 and the 4 switch outputs work normally while the signal strength output is selected.

Table of Output Current vs Signal Level in dBm

Current	Output	RF Level
	mA	-dBm
18.8		-35 Highest Readable Level
18.4		-40
18.0		-45
17.9		-50
17.6		-55
17.3		-60
17.0		-65
16.4		-70
16.0		-75
15.5		-80
15.0		-85 20dB Safety Margin
14.0		-90
12.8		-95
11.0		-100
9.0		-105
7.3		-107 Receiver Threshold

## Case Dimensions INCHES [mm]

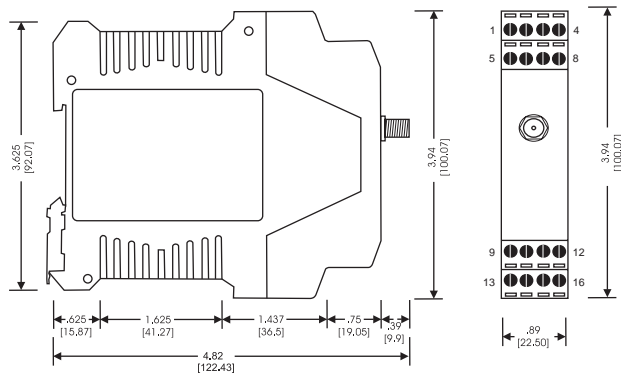

## Terminal Connections

### DR9011-01 Dual DC Input

TERMINAL	CONNECTION
1	DC Input 1 +
2	DC Input 1 -
3	DC Input 2 +
4	DC Input 2 -
5	Switch 1 +
6	Switch 1 -
7	Switch 2 -
8	Switch 2 +
9	Switch 3 +
10	Switch 3 -
11	Switch 4 -
12	Switch 4 +
13	No Connection
14	No Connection
15	DC Power +
16	DC Power -

### DR9011-02 Bridge Input

TERMINAL	CONNECTION
1	Input +
2	Input -
3	No Connection
4	Shield
5	Switch 1 +
6	Switch 1 -
7	Switch 2 -
8	Switch 2 +
9	Switch 3 +
10	Switch 3 -
11	Switch 4 -
12	Switch 4 +
13	Excitation +
14	Excitation -
15	DC Power +
16	DC Power -

### DR9011-03 RTD Input

TERMINAL	CONNECTION
1	RTD +
2	RTD Common
3	RTD Common
4	Shield
5	Switch 1 +
6	Switch 1 -
7	Switch 2 -
8	Switch 2 +
9	Switch 3 +
10	Switch 3 -
11	Switch 4 -
12	Switch 4 +
13	No Connection
14	No Connection
15	DC Power +
16	DC Power -

### DR9021

TERMINAL	CONNECTION
1	4/20mADC Output 1 +
2	4/20mADC Output 1 -
3	4/20mADC Output 2 +
4	4/20mADC Output 2 -
5	Switch 1 OC Collector
6	Switch 1 OC Emitter
7	Switch 2 OC Collector
8	Switch 2 OC Emitter
9	Switch 3 OC Collector
10	Switch 3 OC Emitter
11	Switch 4 OC Collector
12	Switch 4 OC Emitter
13	No Connection
14	No Connection
15	DC + or AC L1 Power
16	DC - or AC L2 Power

Figure 2

DR9011 and DR9021 Case Dimensions and Terminal Connections

## INSTALLATION

The DR Series of products mount on standard 35 mm DIN rails. Install by hooking the top of the case's latch onto the top of the DIN rail. Then push down on the case, letting it pivot on the DIN rail. The bottom slide of the mount will snap behind the rail and secure the product.

To remove, insert a screwdriver into the hole on the metal latch on the bottom of the case, and pull the latch down until it allows the front of the case to be lifted up.

The enclosure depth must be deep enough to accommodate the antenna connector and cable. See Figure 2 for details of the case dimensions.

**Note:** Correctly identify the DR9011 and DR9021 and note power requirements before snapping onto the DIN Rail. Once installed the side label may not be visible.

## CONNECTING TO THE DR9011 TRANSMITTER

### ANALOG INPUTS

The DR9011 accepts dual DC, single RTD or single bridge analog inputs as noted on the label located on the right side of the product. Refer to this label to determine the input type and range that the product is configured to receive.

Figure 2 shows the terminal connections for the DR9011. The following diagram shows a typical configuration for wiring the analog input channels.

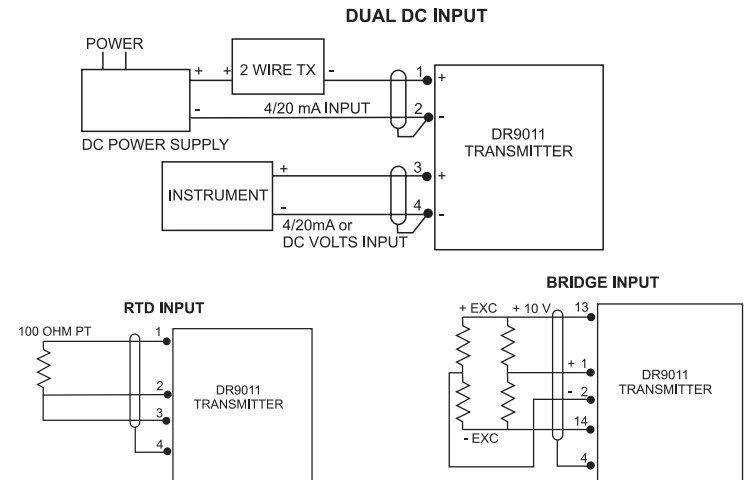

### SWITCH INPUTS (DR9011)

The DR9011 accepts four discrete inputs. Refer to Figure 2 for location of the termination connections. These are dry contacts or open collectors that require no external supply voltage. The DR9011 supplies voltage across the switch inputs equal to the power supply voltage. Applying external voltage across the switch inputs will result in damage to the DR9011 and will void the warranty.

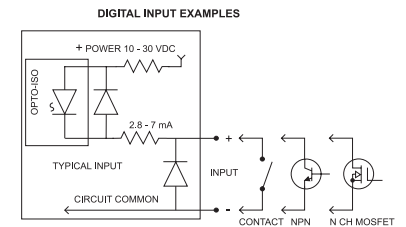

## CONNECTING TO THE DR9021 RECEIVER

### ANALOG OUTPUTS

The DR9021 outputs two 4/20mADC analog signals proportional to the inputs of the DR9011. The outputs are 12VDC compliant. Figure 2 shows the terminal connections for the DR9021.

### SWITCH OUTPUTS (DR9021)

The DR9021 provides four switch outputs as isolated open collector NPN transistors. Refer to Figure 2 for location of the termination connections. These are open collector transistors. Do not connect more than 28VDC across the terminals and only install the relay coil on the positive terminal. The following diagram shows a typical configuration for wiring a relay to the switch outputs.

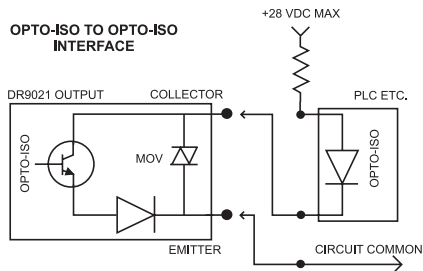
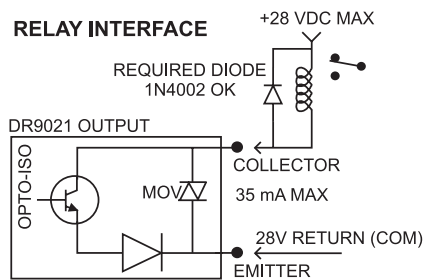

## CONNECTING POWER TO THE DR9011 AND DR9021

**WARNING:** Before connecting power to either unit, read the label to ensure the correct power is being supplied. Note the DR9021 is available in both AC and DC power configurations. Applying the wrong power will damage the product.

Once the proper power requirement is determined for each unit, connect the power leads to the terminal connections as shown in Figure 2. Note The DR9011 does not have a power LED. Once powered the red LED should begin to flash indicating that the unit is powered and transmitting.

### TERMINAL CONNECTIONS

Once wired, the terminal blocks can be unplugged as necessary for maintenance, eliminating the need for disconnecting all wiring. To remove the terminal blocks, simply pry the blocks off their connector pins using a small screwdriver inserted under the front edge of each terminal block.

### CONNECTING THE ANTENNA TO THE DR9011 AND DR9021

The antenna connects to the Reverse Polarity SMA (RPSMA) connector on the front panel of the DR9011 and DR9021. Large cable sizes (400, 600 size cable) should not be directly connected to the product unless the cable can be connected with no stress/strain on the front panel connector.

Three lengths of small diameter cable are available to connect the RF unit to a bulkhead connector. Larger cable can then be used from the bulkhead connector to the antenna.

When connecting the cable to the front panel connector, the connection should hand tight. Ensure that the connection is tight but use of a wrench to tighten beyond hand tight may damage the connector.

### IMPORTANT:

**Lightning is also a primary consideration when attaching outdoor antennas to the receiver. A grounded surge arrester must be connected in the coax line between the antenna and the transmitter. Using an outdoor antenna without a surge suppressor will void the warranty.**

## NORMAL REVERSE ACTING SWITCHES/ALARM (DR9021 ONLY)

Normal logic for the DR9021 digital output is for the NPN transistor to conduct when a switch is closed at the DR9011 transmitter input. Reverse logic will have the NPN transistor not conduct when the DR9011 switch input is closed.

The digital outputs of the DR9021 can be reversed by changing the 4<sup>th</sup> DIP switch setting. To change the switch settings remove all power from the DR9021. Squeeze the two tabs that hold the case front section to the rear section and pull the case apart. The circuit board is attached to the front section and will slide out of the case. Locate the 4 position DIP switch (see Figure 1). For Normal acting alarms, set DIP Switch 4 to SW NORM. For Reverse acting alarms (failsafe) set DIP Switch 4 to SW REV.

### CALIBRATION

The system was factory calibrated and should not require field calibration. If field calibration is required Zero and Span adjustments can be made on the DR9021.

To make field adjustments to the product:

1. Connect a calibrator to the input terminals of the DR9011.

**NOTE:** For Dual 4/20mADC units, calibrate each channel separately.

2. With all power removed from the DR9021 squeeze the two tabs that hold the case front section to the rear section and pull the case apart just far enough to provide access to the Zero and Span pots located near the top edge of the board. The circuit board is attached to the front section and will slide out of the case. **DO NOT REMOVE THE BOARD ANY FARTHER THAN NECESSARY TO ACCESS THE ADJUSTMENTS.**
3. Secure the DR9021 on a work bench or DIN Rail so that the Zero and Span adjustments are easily accessible and ensure that nothing other than the case is touching the circuit board. **WARNING: Once power is applied touching any part of the circuit board may result in electrical shock. Proceed with extreme caution.**
4. Connect an accurate current meter to the output terminal 1 and 2 of the DR9021.

5. Apply power to both units.
6. Watch to see that the green RX LED on the DR9021 is flashing steady. If not refer to the section in this manual on Setting up the RF Link before proceeding.
7. Set the input at the DR9011 for its zero scale and adjust the Channel 0 Zero control on the DR9021 until the current meter reads a 4mADC output.
8. Set the input at the DR9011 for its full scale and adjust the Channel 0 Span control on the DR9021 until the current meter reads a 20mADC output.
9. Repeat once or twice until no further adjustment is required.

*Repeat for the second analog channel (terminals 3 and 4).*

## OPERATION OF THE WIRELESS PEER-TO-PEER SYSTEM

Once all connections are made and power is applied no, other adjustments or controls are required. The red TX LED on the front panel of the DR9011 should be flashing steady indicating that the unit is transmitting an RF signal. The green RX LED on the DR9021 should be flashing steady indicating that the unit is receiving a RF signal.

### SETTING UP THE RF LINK

The DR9011 is designed to repetitively transmit data at a rate of approximately once per 100msec. The signal levels and switch status are sampled, digitized, and sent out through the RF. All DR9021's within range and set to the same Hop Sequence of the DR9011 will receive the signal and reconstruct the signal levels and switch status. The DR9021 is receiving data when the green RX LED is flashing. The green RX LED should flash at the same rate as the red TX LED on the DR9011.

With all antennas connected and installed the following step should be taken to ensure that DR9021's are reliability receiving data.

1. Apply power to all units in the area. Remove power from the DR9011 and monitor all DR9021's associated with the DR9011 to ensure that the green RX LED is not flashing. If the RX LED is flashing, change HOP Sequences on both the DR9011 and all DR9021's in this system and repeat this step.

2. Apply power to all units. Check to see that the green RX LED is flashing steady on all DR9021. If the RX LED does not flash or is inconsistent then further steps are needed to obtain a reliable RF signal. Continue to step 3.
3. If the RX LED does not flash or is inconsistent, the antennas, cables, and connectors for both the transmitter and receiver may need to be adjusted, changed or repaired.
  - a. Verify that all antenna cables and connectors are continuous and not shorted. This includes any pigtail cables, bulkhead adapters, lightning surge arrestors, and extension cables.
  - b. Inspect the antennas for damage. Note: Some antennas are shorted across the center pin to shield and some are open. Unless the antenna configuration is known, measuring resistances across the antenna is not useful.
  - c. Verify that the antennas are mounted and aimed correctly. Omni antennas should be vertical and mounted above and free of obstructions. Yagi antennas should be pointed at their companion antennas with the elements vertical. Use of topographical maps and satellite imagery can be very helpful when aiming antennas.
  - d. Verify that the signal path is clear. Any obstructions in the signal's Fresnel zone can reduce the signal strength. Often the signal can pass through or around trees, buildings, and machinery. All of these do reduce the signal strength and excessive obstruction will result in a weak signal. The signal will not penetrate earth. If the ground level rises up into and obstructs the Fresnel zone, the height of the antennas will need to be increased.
  - e. Verify you have selected the proper antenna for the application. For help with antenna selection contact Wilkerson Instrument Company, Inc.

A copy of our Wireless Engineering Manual can be downloaded from [www.wici.com](http://www.wici.com) or obtained from the factory by contacting [sales@wici.com](mailto:sales@wici.com).

### RF SIGNAL LOSS

If for any reason the RF signal is lost for 2 seconds or more the analog outputs of the DR9021 will drop to below 4mADC. The switches will move to the failed position as defined by the 4<sup>th</sup> DIP Switch described above. Often applications will use one of the switch contacts as a failed RF signal alarm or they will monitor the analog value and alarm when the value drops below 4mADC.

### OPEN SENSOR INPUT

The DR9021 is designed for an up scale burn out if the analog inputs of the DR9011 become open. If the input load to the DR9011 is removed the output of the DR9021 will be above 20mADC. Applications use this feature to monitor the sensor status.

### APPLICATIONS

The DR9011 and DR9021 have numerous applications where an analog signal and/or an alarm contact needs to be monitored and the installation of signal wire between the locations is not practical or cost prohibitive. This system has been successfully installed in many applications where a signal needs to be transmitted a short distance between machinery as well as longer range application where signals are transmitted up to 20 miles. Visit <http://www.wici.com> or call Wilkerson Instrument Company, Inc. for more information on successful applications using Wireless products.

### FCC WARNING

This device complies with Part 15 of the FCC Rules. Operation is subject to the following two conditions (1) this device may not cause harmful interference and (2) this device must accept any interference received, including interference that may cause undesired operation.

### WARRANTY

The DR9011 and DR9021 carry a limited 5 year warranty (1 year on the radio module). In the event of a failure due to defective material or workmanship, the unit will be repaired or replaced at no charge.

## SPECIFICATIONS

### DR9011 TRANSMITTER INPUTS

Dual DC Voltage or Current	
Current	Voltage
Min Span = 1 mA	Min Span = 100 mV
Max Span = 50 mA	Max Span = 150 V

Accuracy	Linearity
±0.1% of span	±0.05% of span

Common Mode Rejection  
= 100 dB, DC to 60 Hz

RTD Input – 100 ohm Pt  
Min Span = 50°C  
Max Span = RTD Limit  
Linearity vs Temperature  
= 0.1% / °C of span  
Accuracy = ±0.1% of span

Bridge Input  
Min Span = 0.5mV/V (10V excitation)  
Max Span = 100mV/V  
Linearity = ±0.05% of span  
(referenced to V in)  
Excitation Supply = 10.00V, 125mA max  
(Drive four 330 ohm bridges in parallel)

Switch Input  
Open Circuit Voltage Closed Circuit Current  
10 to 30 VDC 3 to 9 mA

I/O Data Rate Tx to Rx  
Update Rate = 10/S

### DR9021 RECEIVER OUTPUT

Dual 4/20 mA DC  
12V Compliance  
4 optically isolated Open Collector  
NPN transistors  
28V Max  
35mA Max

**OPERATING TEMPERATURE**  
-13°F to 167°F / -25°C to 75°C

**TEMPERATURE STABILITY**  
± (0.01% of span)/°C max

**POWER**  
DR9011  
10 to 30 VDC, 1.5 Watts Max  
DR9021  
85 to 240 VAC, 2.0 VA Max  
12 or 24 VDC, 1.5 Watts Max

Specifications Are Subject To Change Without Notice. © 2009 Wilkerson Instrument Co., Inc. DWG# W104066B 11/09



### RADIO

Frequency  
910 - 917 MHz (Standard)  
920 - 927 MHz (Optional)  
2.4000 - 2.4835 GHz

Transmit Output Power  
900 and 923MHz  
100mW (20dBm)  
2.4GHz  
50mW (17dBm)

Receiver Sensitivity  
900 and 923MHz  
-110dBm  
2.4GHz  
-105dBm

Spread Spectrum Type,  
Frequency Hopping, Direct FM  
7 Hop Sequences per Frequency

Range (Line of Sight)  
900 MHz —  
Up to 20 Mi. with high gain antennas  
2.4GHz —  
Up to 10 Mi. with high gain antennas

Antenna Connector  
Reverse Polarity SMA Female

### CERTIFICATIONS

RF Module — FCC Part 15.247  
DR9011 and DR9021 — UL/cUL Recognized

### SUPPORT

Wilkerson Instrument Company, Inc. wants to help you get the most from your system. If there is anything we can do, please call or fax us.

Telephone: 863-647-2000  
Fax: 863-644-5318  
Or, you can email us: [sales@wici.com](mailto:sales@wici.com)  
Or you can visit our website:  
[www.wici.com](http://www.wici.com)

On the website you'll find application notes, product manuals, engineering manuals, and a complete listing of our products.

2915 Parkway Street  
Lakeland, FL 33811-1391 · USA

800-234-1343

Tel: 863-647-2000 · Fax: 863-644-5318  
[www.wici.com](http://www.wici.com) · E-mail: [sales@wici.com](mailto:sales@wici.com)