

DR4302
DC INPUT
DUAL 4/20 mA OUTPUT
(SPLITTER)
ISOLATED TRANSMITTER
DIN RAIL MOUNT



DESCRIPTION

The DR4302 provides two individually isolated DC current outputs proportional to a DC voltage or current input. The input and output are ranged at the factory, but Zero and Span controls provide $\pm 15\%$ adjustability.

The DR4302 provides 3 way isolation between input, output, and power source.

The isolation makes the product useful for measuring input signals with high common mode voltages and for breaking ground connections to eliminate ground loops. It can also be used for signal conversion and scaling as well.

The screw terminal blocks plug into the case, which allows easy wiring and removal of products.

All of the DR Series of products provide transient protection to help eliminate damage from lightning and from other transients coupled onto the power and signal leads by system wiring.

INSTALLATION

The DR Series of products mount on standard 35 mm DIN rails. Install by hooking the top of the case's latch onto the top of the DIN rail. Then push down on the case, letting it pivot on the DIN rail. The bottom slide of the mount will snap behind the rail and secure the product.

To remove, insert a screwdriver into the hole on the metal latch on the bottom of the case, and pull the latch down until it allows the front of the case to be lifted up.

WARRANTY

The DR4302 Series of products carry a limited 5 year warranty. In the event of a failure due to defective material or workmanship, the unit will be repaired or replaced at no charge.

CALIBRATION

The DR4302 is factory calibrated to the input and output noted on the case side label. Terminal connections are shown on the front label.

To make field adjustments to the product:

1. Remove the circuit board from the case by squeezing the 2 locking tabs (see diagram below) and pulling the case front, with the circuit board, out of the case.
2. Connect a calibrator to the input terminals.
3. Connect an accurate voltmeter or current meter to the Output 1 terminals.
4. Apply power to the unit.
5. Set the input for its zero scale and adjust the Zero control for zero scale output.
6. Set the input for its full scale and adjust the Span control for full scale output.
7. Repeat once or twice until no further adjustment is required.
8. Repeat steps 3 through 7 for Output 2.

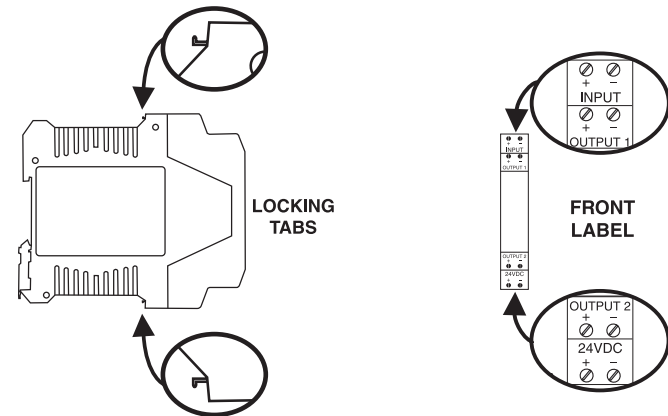

SPECIFICATIONS

INPUT RANGE

Voltage
1/5 V, 0/10 V

Current
0/1 mA, 0/20 mA
4/20 mA, 10/50 mA

INPUT IMPEDANCE

Voltage
=> 170 kilohms

Current	Current Input Value	Input Shunt
	0/1 mA	1000 OHM
	0/20 mA	100 OHM
	4/20 mA	124 OHM
	10/50 mA	20 OHM

OUTPUT

Current
4/20 mA
Compliance > 12 V Per Output
at 24 V Power

BANDWIDTH

-3db at 3 Hz

OUTPUT RIPPLE

(peak to peak)
<0.1% of span

ACCURACY

±0.1% of span

LINEARITY

±0.05% of span

COMMON MODE REJECTION

100 dB, DC to 60 Hz

ISOLATION, OUTPUT/INPUT/POWER

>500 megohms
1000 VPeak

OPERATING TEMPERATURE

14°F to 158°F/-10°C to 70°C

TEMPERATURE STABILITY

±(0.01% of span)/°C max

POWER

21 to 28 VDC, 60 mA max
10 to 15 VDC, 120 mA max

TWO-WIRE TRANSMITTER WIRING

In installations where isolation between the power supply and the input terminals is not required, the DR Series power supply can also be used to power a Two-Wire Transmitter (see drawing below). If isolation is required, a separate power supply must be used to power the Two-Wire Transmitter.

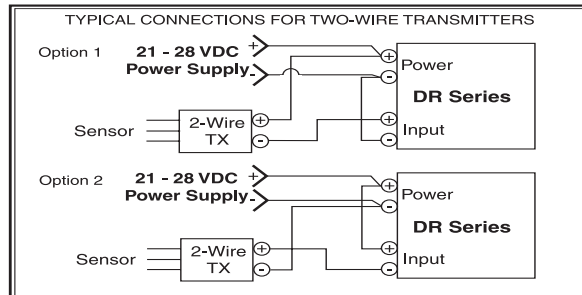

CASE DIMENSIONS INCHES [mm]

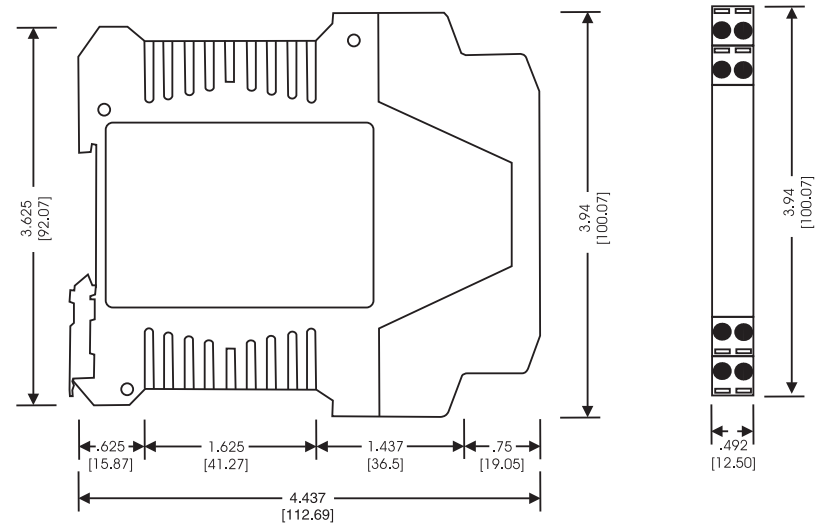

BLOCK DIAGRAM AND PIN CONNECTIONS

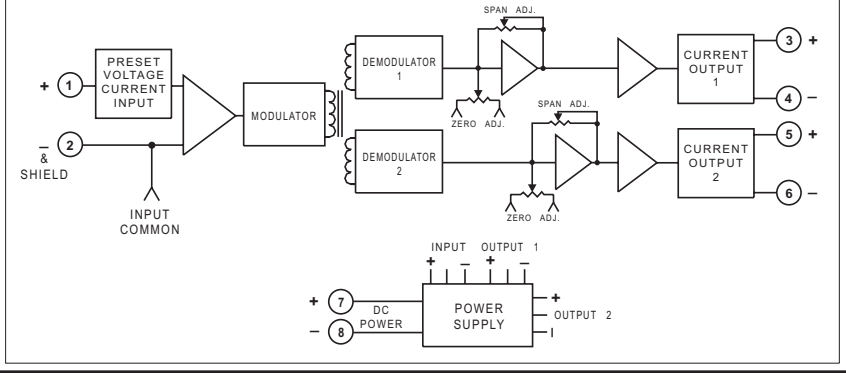

Specifications Are Subject To Change Without Notice. © 2012 Wilkerson Instrument Co., Inc. DWG#W103853 8/12



2915 Parkway Street
Lakeland, FL 33811-1391 · USA

800-234-1343

Tel: 863-647-2000 · Fax: 863-644-5318
www.wici.com · E-mail: sales@wici.com